

## TTA-ASW100H-JJ

AWS with 700 Bypass | Twin TMA | AISG v1.1 or v2.0 | Fixed Gain

- AWS with 700 Bypass, twin TMA, AISG v1.1 or v2.0, fixed gain
- Increases coverage and capacity
- Helps to minimize site acquisition issues
- Reduces the cost of network expansion

RF Characteristics		
Downlink (TX) Path		
Frequency Band	2110-2170 MHz	
Insertion Loss (average)	698-746 MHz	< 0.15 dB
	2110-2170 MHz	< 0.4 dB
Return Loss	698-746 MHz	≥ 18 dB
	2110-2170 MHz	≥ 18 dB
Input Power (dBm)	< 160 CW / < 2000 (+63 dBm) Peak	
Intermodulation (2x43 dBm TX carrier)	≤ -110 dBm in RX band	
Uplink (RX) Path		
Frequency Band	1710-1770 MHz	
Return Loss	DC On	≥ 18 dB
	DC Off	≥ 13 dB
Gain (fixed)	12 dB ± 1 dB	
Noise Figure (average)	< 1.5 dB	
Insertion Loss, Bypass Mode (DC Off)	≤ 2.5 dB	
Output 1 dB Compression	≥ 8 dBm (12dB Gain)	
Power Supply and Alarm		
DC Supply Voltage	8.5 to 30 V	
Alarm Management	AISG Protocol	
Power Consumption	Normal Operation	< 3.2 W
	Active Alarm	< 7.5 W
Environmental Characteristics		
Operating Temperature Range	-40° to +65° C (-40° to +149° F)	
Ingress Protection	IP67	
EMC	ETS 300 342-3	
Lightning Protection	10 kA (8/20 μs)	
MTBF (minimum)	> 1 Mh	



Quoted performance parameters are provided to offer typical or range values only and may vary as a result of normal manufacturing and operational conditions. Extreme operational conditions and/or stress on structural supports is beyond our control. Such conditions may result in damage to this product. Improvements to product may be made without notice.

## TTA-ASW100H-JJ

AWS with 700 Bypass | Twin TMA | AISG v1.1 or v2.0 | Fixed Gain

Mechanical Characteristics			
Dimensions - Length x Width x Depth (without brackets)		215 x 254 x 64 mm	8.5 x 10.0 x 2.5 in
Weight (with brackets)		≤ 6.7 kg	≤ 14.8 lbs
Packing Dimensions		290 x 290 x 200 mm	11.4 x 11.4 x 7.9 in
Packing Weight		≤ 7.5 kg	≤ 16.5 lbs
Connectors (number, type)	BTS	(2x) 7/16-DIN Female / Long Neck	
	ANT	(4x) 7/16-DIN Female / Long Neck	
	AISG	1 / 8 pin circular / Female / IEC 60130-9	
Mounting Characteristics		Mast Diameter	
Wall or Mast Mounting		Ø30-Ø125 mm	Ø1.2-Ø4.9 in
Block Diagram			

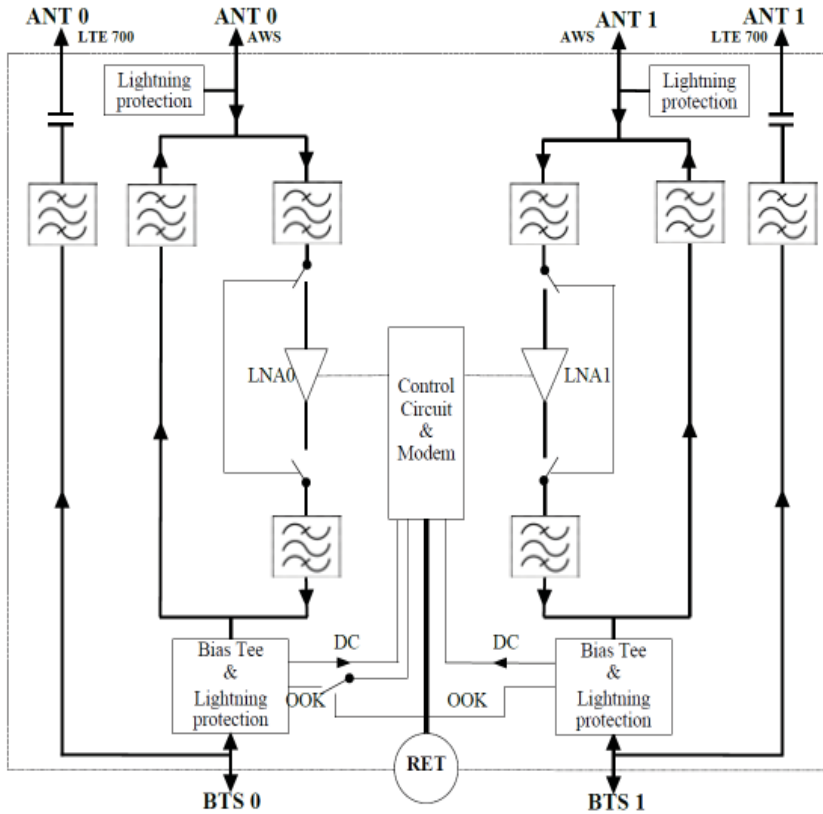

Quoted performance parameters are provided to offer typical or range values only and may vary as a result of normal manufacturing and operational conditions. Extreme operational conditions and/or stress on structural supports is beyond our control. Such conditions may result in damage to this product. Improvements to product may be made without notice.