

300PTR-C-NC

TNC Male Right Angle for CNT-300 and 5D-FB braided cable



OBSOLETE

Product Classification

Product Type	Braided cable connector
Product Brand	CNT®

General Specifications

Body Style	Right angle
Inner Contact Attachment Method	Captivated
Inner Contact Plating	Gold
Interface	TNC Male
Outer Contact Attachment Method	Clamp
Outer Contact Plating	Trimetal

Dimensions

Height	40.99 mm 1.614 in
Width	17 mm 0.669 in
Length	33.31 mm 1.311 in
Nominal Size	0.300 in

Outline Drawing

300PTR-C-NC

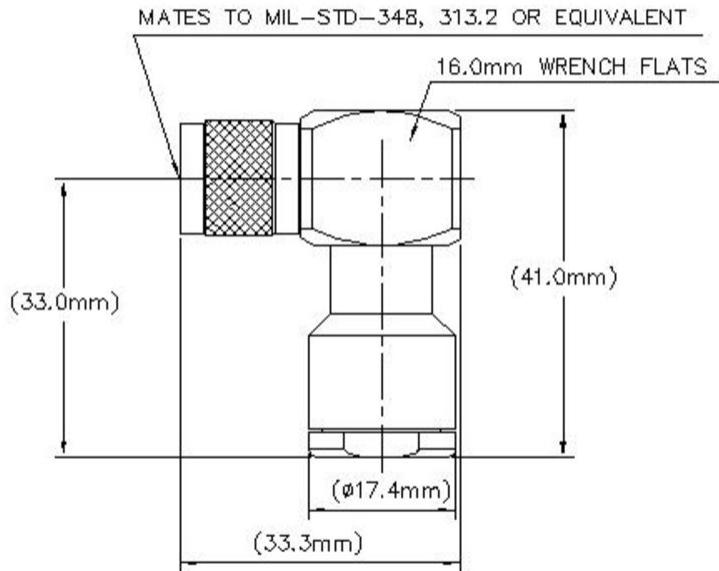

Electrical Specifications

Insertion Loss, typical	0.05 dB
Average Power at Frequency	360.0 W @ 900 MHz
Cable Impedance	50 ohm
Connector Impedance	50 ohm
dc Test Voltage	1500 V
Inner Contact Resistance, maximum	1.5 mOhm
Insulation Resistance, minimum	5000 MOhm
Operating Frequency Band	0 – 6000 MHz
Outer Contact Resistance, maximum	0.4 mOhm
Peak Power, maximum	5 kW
RF Operating Voltage, maximum (vrms)	500 V

300PTR-C-NC

VSWR/Return Loss

Frequency Band	VSWR	Return Loss (dB)
0–500 MHz	1.065	30.05
500–1000 MHz	1.052	31.93
1000–2000 MHz	1.083	28
2000–6000 MHz	1.288	18.01

Mechanical Specifications

Connector Retention Tensile Force	220 N 49.458 lbf
Connector Retention Torque	0.45 N-m 3.983 in lb
Coupling Nut Proof Torque	1.7 N-m 15.046 in lb
Coupling Nut Proof Torque Method	IEC 61169-17:9.3.6
Coupling Nut Retention Force	445 N 100.04 lbf
Coupling Nut Retention Force Method	IEC 61169-17:9.3.11
Interface Durability	500 cycles
Interface Durability Method	IEC 61169-17:9.5
Mechanical Shock Test Method	IEC 60068-2-27

Environmental Specifications

Operating Temperature	-40 °C to +85 °C (-40 °F to +185 °F)
Storage Temperature	-65 °C to +125 °C (-85 °F to +257 °F)
Average Power, Ambient Temperature	40 °C 104 °F
Average Power, Inner Conductor Temperature	100 °C 212 °F
Climatic Sequence Test Method	IEC 60068-1
Corrosion Test Method	IEC 60068-2-11
Damp Heat Steady State Test Method	IEC 60068-2-3
Immersion Depth	1 m
Immersion Test Mating	Mated
Immersion Test Method	IEC 60529:2001, IP68
Thermal Shock Test Method	IEC 60068-2-14
Vibration Test Method	IEC 60068-2-6

Packaging and Weights

300PTR-C-NC

Weight, net

68.93 g | 0.152 lb

Regulatory Compliance/Certifications

Agency

ISO 9001:2015



Classification

Designed, manufactured and/or distributed under this quality management system

* Footnotes

Immersion Depth

Immersion at specified depth for 24 hours

Insertion Loss, typical

$0.05\sqrt{\text{freq}}$ (GHz) (not applicable for elliptical waveguide)