

TA-DMHM

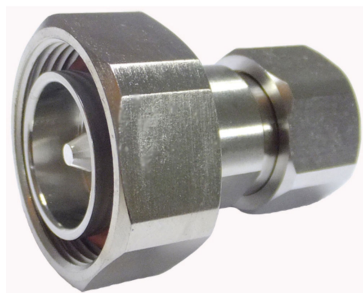

7-16 DIN Male to 4.3-10 Male Low-PIM Adapter

Product Classification

Product Type Adapter

General Specifications

Body Style Straight

Inner Contact Plating Silver

Interface 7-16 DIN Male

Interface 2 4.3-10 Male

Mounting Angle Straight

Outer Contact Plating Trimetal

Dimensions

Length 45 mm | 1.772 in

Diameter 34.6 mm | 1.362 in

TA-DMHM

Outline Drawing

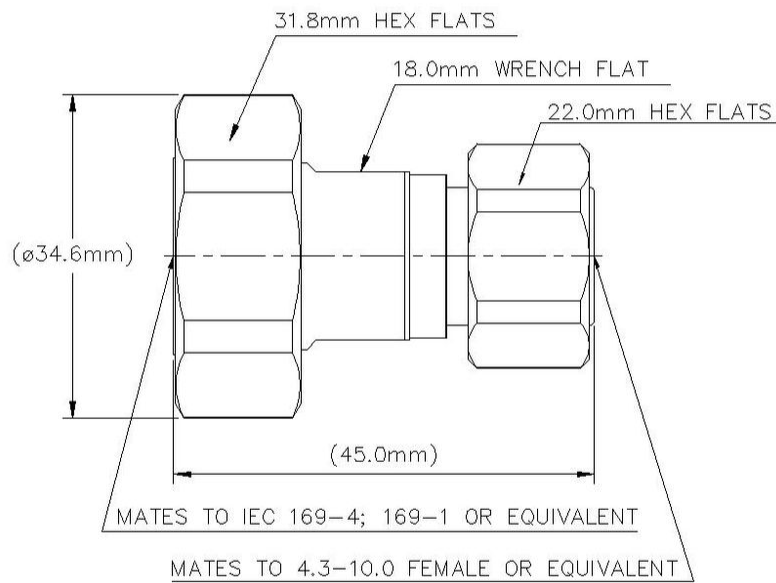

Electrical Specifications

3rd Order IMD at Frequency	-163 dBc @ 1800 MHz
3rd Order IMD Test Method	Two +43 dBm carriers
Cable Impedance	50 ohm
Connector Impedance	50 ohm
dc Test Voltage	2500 V
Inner Contact Resistance, maximum	1 mOhm
Insulation Resistance, minimum	5000 MOhm
Operating Frequency Band	0 – 6000 MHz
Outer Contact Resistance, maximum	1 mOhm

TA-DMHM

VSWR/Return Loss

Frequency Band	VSWR	Return Loss (dB)
0–4000 MHz	1.06	32
4000–6000 MHz	1.09	28

Mechanical Specifications

Coupling Nut Proof Torque	35 N-m 309.776 in lb
Coupling Nut Proof Torque Method	IEC 61169-4:9.3.6
Coupling Nut Proof Torque, Interface 2	7 N-m 61.955 in lb
Coupling Nut Retention Force	1000 N 224.809 lbf
Coupling Nut Retention Force Method	IEC 61169-4:9.3.11
Coupling Nut Retention Force, Interface 2	450 N 101.164 lbf
Interface Durability	100 cycles
Mechanical Shock Test Method	IEC 60068-2-27

Environmental Specifications

Operating Temperature	-55 °C to +85 °C (-67 °F to +185 °F)
Storage Temperature	-65 °C to +125 °C (-85 °F to +257 °F)
Average Power, Ambient Temperature	40 °C 104 °F
Average Power, Inner Conductor Temperature	100 °C 212 °F
Climatic Sequence Test Method	IEC 60068-1
Corrosion Test Method	IEC 60068-2-11
Damp Heat Steady State Test Method	IEC 60068-2-3
Thermal Shock Test Method	IEC 60068-2-14
Vibration Test Method	IEC 60068-2-6

Packaging and Weights

Weight, net	104.64 g 0.231 lb
--------------------	---------------------

Regulatory Compliance/Certifications

Agency	Classification
CHINA-ROHS	Below maximum concentration value
ISO 9001:2015	Designed, manufactured and/or distributed under this quality management system

TA-DMHM

REACH-SVHC

Compliant as per SVHC revision on www.commscope.com/ProductCompliance

ROHS

Compliant

